

Design of Large Cantilever Structure of Independent Column

Hongyuan Xiong^{1, a}

¹China University of Geosciences (Beijing), Beijing, 100083, China

^azlybns@163.com

Abstract

This project is based on the original stand of China University of Geosciences Stadium. First, the original concrete canopy is removed, and then a steel structure canopy is added to the stand. The overall structure adopts a steel pipe truss structure, and the roof maintenance material adopts a single-layer reticulated shell supporting membrane structure. This structure is a large cantilevered structure with independent columns. In order to reduce the vertical displacement of the canopy structure, the vertical and horizontal truss structure is adopted, and the double-column joint foundation form is adopted to improve the overall stability of the structure. According to the bearing capacity requirements of the whole structure under the action of wind load and other live loads, the force analysis of the structural members is carried out, including the analysis of the overall vertical deformation of the structure, the stress analysis, and the force analysis under the action of earthquakes. This structure is a large cantilevered independent column structure, and the stability control of the overall structure must meet the requirements of the specification. The buckling modes of the structure are analyzed. The buckling analysis results show that the structure does not suffer from overall instability under normal service loads.

Keywords

Cantilever structure; Stress ratio; Deformation; Buckling analysis.

1. INTRODUCTION

The stadium canopy structure generally adopts a semi-covering method, and the coverage generally depends on the size of the stand [1]. Commonly used stand canopy structures include reinforced concrete structure and steel structure canopy. The structural form and safety degree of the canopy structure have always been the focus of people's research. In addition, the roof form of the canopy is equally important, considering both the lighting effect and the overall stress characteristics. Therefore, an economical and practical stadium canopy structure should not only pay attention to the safety and simplicity of the structure, but also pay attention to the visual effect of the appearance. This paper adopts the combined form of steel canopy and roof membrane structure.

China University of Geosciences is located on Xueyuan Road, Haidian District, Beijing, where famous schools gather. It is a well-known institution of higher learning at home and abroad. This project is the structural design of the new canopy for the playground stand of China University of Geosciences. Figure 1 shows the stand canopy that has been constructed.



Figure 1. Stadium grandstand canopy

2. STRUCTURAL ANALYSIS

2.1. Structure Type

The main structure of the new stand canopy adopts a steel pipe truss structure, which is composed of a horizontal truss, a longitudinal truss, an inter-column support and a roof support to form a spatial structure system. The transverse truss adopts double-limb lattice beams and columns, each of which is connected by longitudinal trusses, and each group of lattice columns is connected by horizontal trusses. The maximum cantilever length of the transverse truss is about 15 meters. In the middle part of the canopy, the span of the transverse trusses on both sides is about 12 meters, and the whole is a symmetrical structure; section. The roof maintenance material adopts a single-layer lattice shell supporting membrane structure. The overall model of the canopy is shown in Figure 2, and the single-product truss structure is shown in Figure 3.

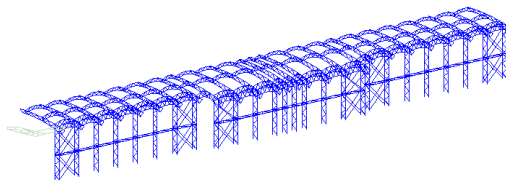

Figure 2. Integral model of Stadium Canopy

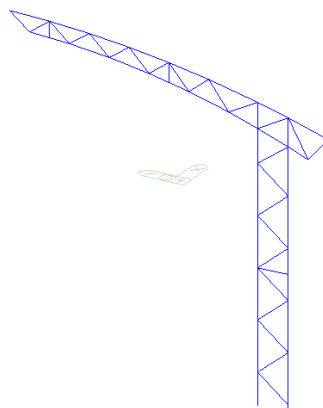

Figure 3. Cantilever single truss model

2.2. Design Key Points

The cantilever structure is a relatively common structural form in stadiums. According to the relationship between the canopy and the stand, it can be divided into two types: supported by the stand and separated from the stand. The cantilever structure is a form separated from the stand. condition related. This structure needs to meet the requirements of strong and rigid

connection at the bottom of the column and rigid connection of the beam-column joints. The structures that use this form include the National Stadium (Bird's Nest) and the Shanghai Oriental Sports Center's heart pool.

The cantilever canopy needs to solve the following key problems: 1) The anti-overturning of the main structure, the independent foundation under the column and the joint foundation form, effectively resist the overturning force couple; 2) Effectively play the role of space to achieve vertical deformation coordination and internal force Redistribution to enhance the redundancy of the structural bearing capacity; 3) Consider the influence of wind load on the structure, especially to ensure the overall stability of the roof membrane structure under the action of wind suction.

For a relatively large cantilevered structure, its structural form is different from that of a closed structure: light weight, high flexibility, low damping, and low natural vibration frequency [2]. These characteristics make wind load the most important form of load in structural design.

2.2.1 Force Analysis

(1) Load condition

Constant load: The load of the reticulated shell of the membrane structure and supporting membrane structure is 0.25kN/m², which is added to the top chord of the transverse truss in the form of line load.

Live load: The live load is 0.5kN/m², which is added to the top chord of the transverse truss in the form of line load.

Wind load: The structure adopts the basic wind pressure of 0.45kN/m² once in 50 years, and the ground roughness is Class B; The inclination is about 15°, and the body shape coefficient is taken as 1.35;

Snow load: The basic snow pressure is 0.4kN/m².

Earthquake action: The seismic fortification intensity is 8 degrees (basic seismic acceleration is 0.2g), class III sites, and the design earthquakes are grouped into the first group.

(2) Force characteristics

Under the action of the standard combination, the maximum vertical deformation of the whole structure occurs at the position of the maximum span in the middle, as shown in Figure 4. The maximum cantilever length is about 15m, and the maximum vertical deformation value is 128mm, so the deformation/span=128/15000x2=1/234<[1/150], and the vertical displacement meets the specification requirements.

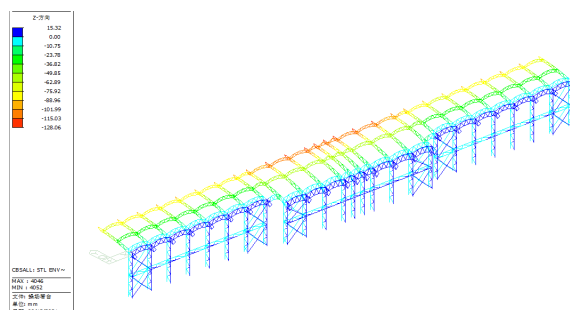

Figure 4. Vertical displacement diagram of canopy

The overall stress ratio of the structure is shown in Figure 5. It can be seen that the stress ratio of all rods is below 0.8, and the bearing capacity meets the requirements, indicating that the canopy structure has a significant spatial effect, good stability, and overall safety.

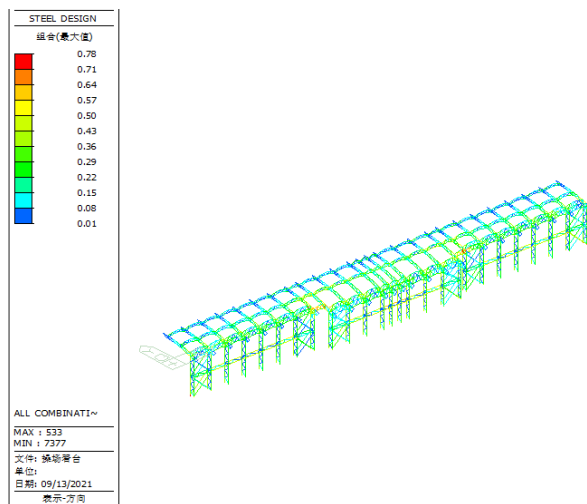

Figure 5. Overall stress ratio of canopy

The overall natural vibration period of the canopy is shown in Figure 6. It can be seen that the natural vibration period of the canopy dominated by vertical vibration is less than 1.0s, indicating that the vertical stiffness is good.

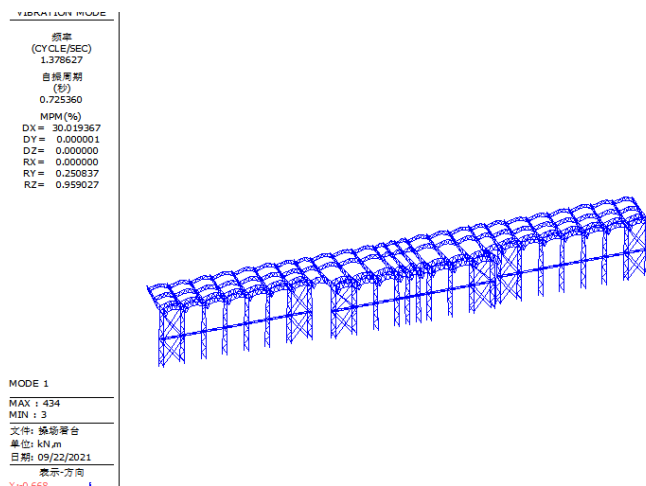

Figure 6. Overall natural vibration period of canopy

2.3. Buckling Analysis

This project is a large cantilevered structure with independent columns. The independent columns are in the form of double-limb lattice columns and one-way large cantilevered membrane roofs. This kind of structure is prone to warping deformation under the action of external loads. Therefore, in addition to the analysis of the overall stress and deformation of the structure, the buckling mode of the overall structure should also be analyzed. Buckling analysis is a technique for determining the buckling modes and critical loads at which a structure begins to become unstable [4].

In this section, a single load is used to apply a small disturbance to the structure when the structure reaches equilibrium, and the overall stability of the structure is analyzed. The linear buckling mode and the load factor value are considered, and the numerical change of the initial defect and the effect of different loads are studied. influence of structure.

This analysis only considers the linear buckling mode, which is an ideal state for the structure, so there is a certain deviation, it is only used to improve the structure, and its vertical front six-order buckling mode is obtained under the action of gravity and live load. As shown in Figure 7.

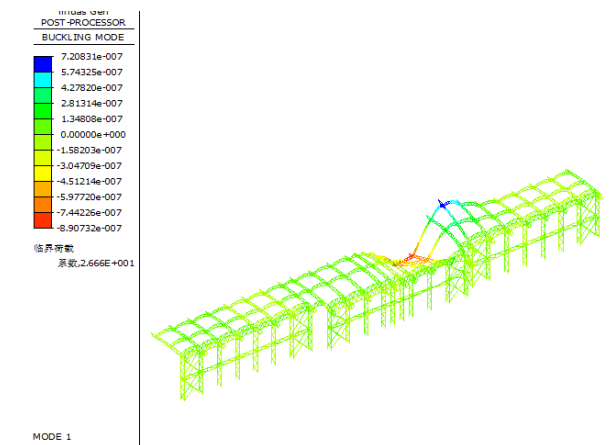

(a) 1st Model

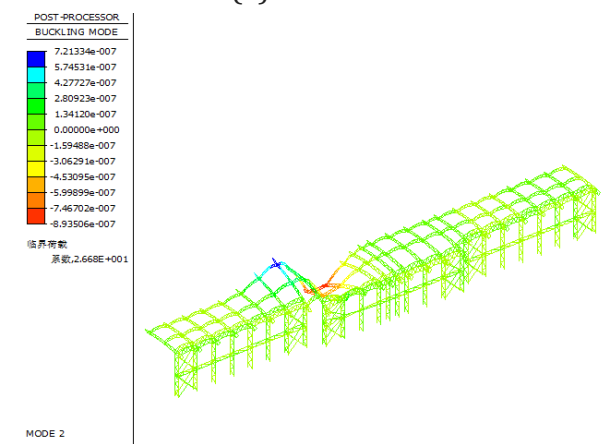

(b) 2nd Model

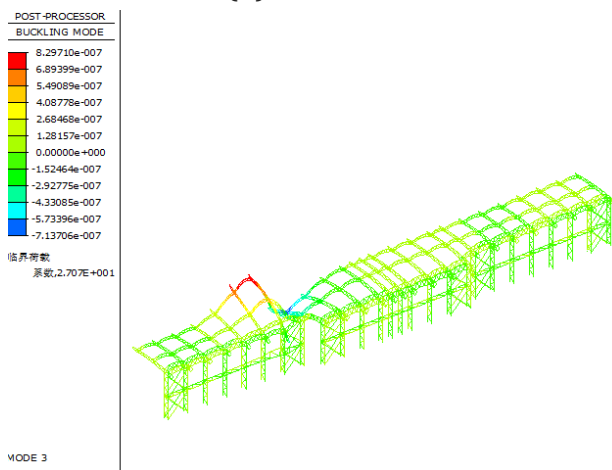

(c) 3rd Model

Figure 7. Buckling mode diagram

According to this buckling analysis, the critical load coefficient under each order buckling model, that is, the eigenvalue coefficient, is obtained. The buckling of each stage occurs at the position of the roof transverse truss rod, and every two order buckling modes are symmetrically distributed. The stability of this structure is analyzed from the buckling coefficient in Table 2.1. It can be seen that the stability coefficient of the structure is far greater than 4~5, so the overall instability of the structure will not occur when the load is normally used.

Table1. Summary of buckling coefficients

Buckling Model	Buckling Factor	Buckling Shape
1	26.67	Vertical bucking
2	26.68	Vertical bucking
3	27.07	Vertical bucking
4	27.16	Vertical bucking
5	29.86	Vertical bucking
6	29.87	Vertical bucking

3. CONCLUSION

This project belongs to the large cantilevered steel structure, and the canopy adopts the steel pipe truss structure. The design and calculation of the canopy of the stadium stand of China University of Geosciences is carried out, and the following conclusions are obtained through the overall force analysis of the structure:

(1) According to the analysis results of the static model, it can be seen that the normal section strength, stress and stiffness of the structure all meet the requirements of the specification, and there is a certain safety reserve.

(2) According to the overall deformation analysis of the structure, the maximum vertical deformation of the canopy is less than 1/150, which meets the requirements of the specification.

(3) From the results of the seismic analysis model, it can be seen that the natural vibration period of the canopy, which is dominated by vertical vibration, is less than 1.0s, which meets the requirements of the specification.

(4) It can be seen from the results of the buckling analysis model that the stability coefficient of the structure is much larger than 4~5, and the overall instability problem of the structure will not occur when the load is normally used.

REFERENCES

- [1] DingJie-min, Zhang Zheng.Recent applications and practices of roof steel structure of stadiums in China.*Building Structure*,2011,v.41;No.328(04):1-6.. (In Chinese)
- [2] Luo Min-jie, Jiang Zhong-jun, Cong Min, Huo Wen-ying.Design and Analysis on the Roof Structure of Wengdeng Center Stadium.*Building Structure*,2009,v.39(S1):93-95. (In Chinese)
- [3] GB50009-2012 Load code for building structures. Beijing: China Architecture & Building Press,2012.
- [4] Wang Dong-hui. Stability Analysis Of Three-way Grid Shell Structure. (Master.D., Xi'an Technological University, 2020), p.54.